

YOSU`S AluBuil/AluAd General Information

AluBuil/AluAd



Aluminum Composite Panel from YoSu for architecture & Signage marketed under the trade-name AluBuil/AluAd are well-known among the clients owing to them great mechanical properties, weather resistance, broad range of choice and stable quality.

The products have excellent sound and heat insulation properties. Its self-extinguishing complies with European Fire Resistance standard - EN13501-1, B1 grade. And can be easily and economically processed with the standard tools and methods used in metal and wood works.

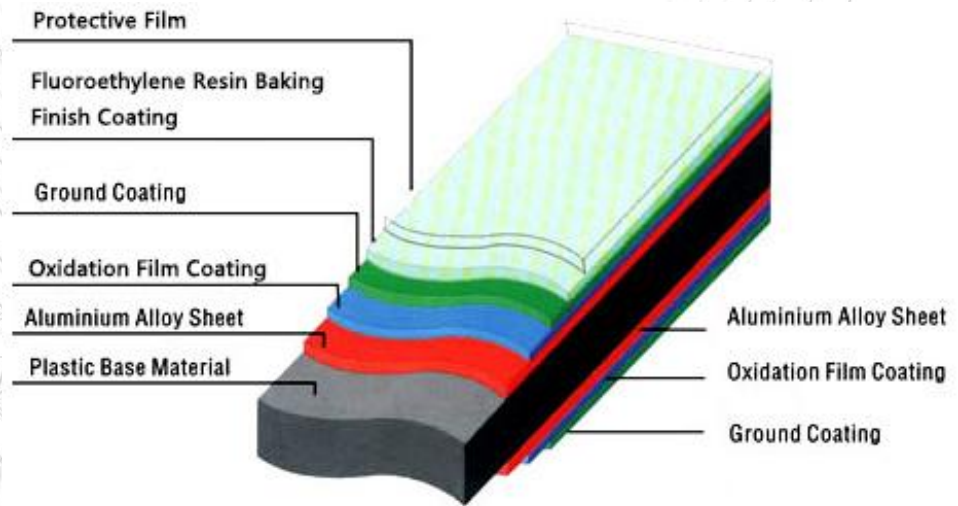

Main Specifications

Width(W)	1220mm, 1250mm, 1500mm, 1570mm
Thickness(T)	2mm, 3mm, 4mm, 6mm
Length(L)	2440mm, 3000mm, 4000mm, 5000mm (L ≤ 5000mm)
Aluminum thickness	0.30mm, 0.35mm, 0.40mm, 0.45mm, 0.50mm
Coating types	PE, PVDF, FEVE
Color	Metallic Silver, Silver Gray, Glossy White, Pure White, etc.

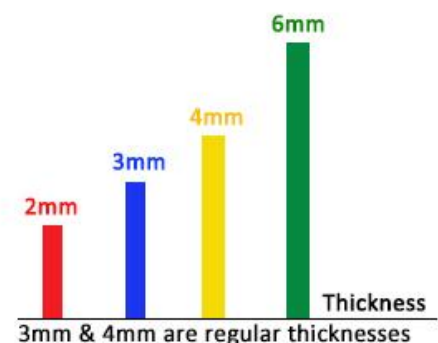

AluBuil Test Date

Items	Standard index of quality product	Result	Conclusion
Appearance	Clean surface without swel, flaw, scratch and aberration	Pass	Qualified
	Length: ±3mm	0mm→+2mm	
	Width: ±2mm	0mm→+2mm	
	Thickness: 0.2mm	0mm	
Deviation of dimension	Deviation of diagonal: ≤ 5mm	1mm	Qualified
	OUT of straight at sides: ≤ 1 mm/m	0.2mm/m	
	Warp: ≤ 5mm	1mm/m	
Thickness of coating	≥ 25µm	29µm (av 30)	Qualified
Deviation of coating	≤ 10	2.1 (av 28.0)	Qualified
Hardness of pencil	≥ HB	3H	Qualified
Toughness of coating	≤ 2T	2T	Qualified
Adhesive	Not less than Grade 1	Squaring of Grade 0, Grade 1 marking method of rolling line	Qualified
Impact strength	50kg·cm Without paint off and crack	Pass	Qualified
Boiling water resistance	Boiling for 2h without change	Unchanged	Qualified
Acid resistance	Immerse surface with 5% HC I (v/v) for 48h without change	Unchanged	Qualified
Alkali resistance	Immerse surface with 5% NaOH I (m/m) for 48h without change	Unchanged	Qualified
Oil resistance	Immerse surface with 20# engine oil for 48h without change	Unchanged	Qualified
Solvent resistance	Clean 100 times with butanone without change	Bottom unrevealed	Qualified
Cleaning resistance	≥ 10000 times with butanone without change	Unchanged	Qualified
Abrasion resistance	≥ 5L/µm	5.33L/µm	Qualified
Density of surface	Specified value:+0.5kg/m ²	5.32kg/m ²	Qualified
Bend strength	≥ 100MPa	121 MPa	Qualified
Flexuous modulus of elasticity	≥ 2.0×10 ⁴ MPa	3.12×10 ⁴ MPa	Qualified
Through resistance	9.0kN	9.94kN	Qualified
Cutting strength	≥ 28.0MPa	32.0MPa	Qualified
180° peel strength	≥ 7.0N/mm	11.2N/mm	Qualified
Resistance to change of temperature	-40°C-80°C, 20 cycles without changes	Unchanged	Qualified
Heat deformation temperature	≥ 95°C	120°C	Qualified
Coefficient of heat expansion	≤ 4.00×10 ⁻⁵ °C ⁻¹	1.98×10 ⁻⁵ °C ⁻¹	Qualified
Salt Haze resistance aberration	Not less than Grade 2	Grade 1	Qualified
Artificial resistance aberration	≤ 3.0	1.24	Qualified
Aging resistance out of light	Not less than Grade 2	Grade 1	Qualified
2000h other aging characteristic	Grade 0	Grade 0	Qualified

AluAd Technical date







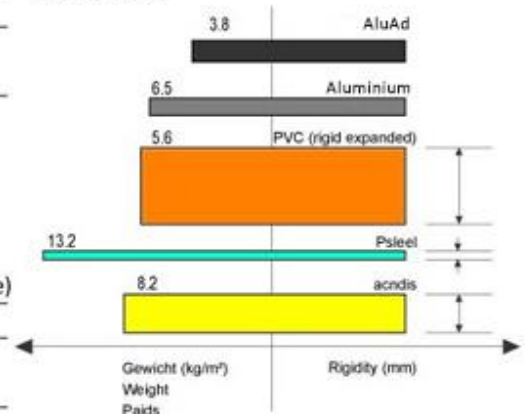











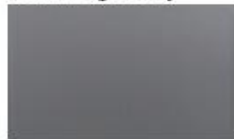



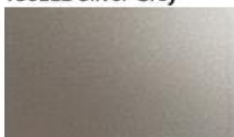





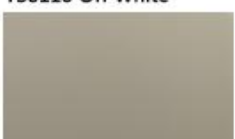

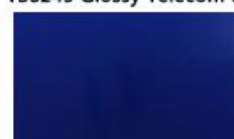



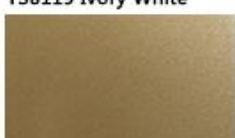

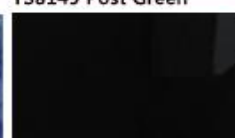
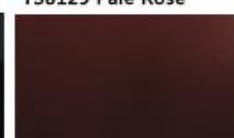
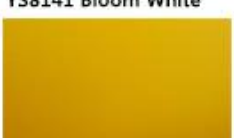

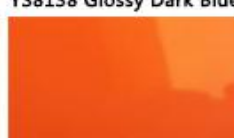

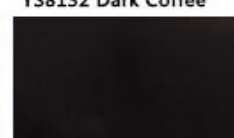





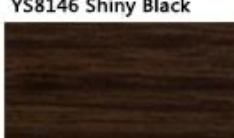

Panel thickness		2 mm	3 mm	4 mm	6 mm
Thickness of Aluminium Layers	(mm)	0.30			
Weight	(kg / m ²)	2.90	3.80	4.7	6.60
Technical Properties:					
Section Modulus	W (cm ³ / m)	0.51	0.81	1.11	1.71
Rigidity (POsson'ratio μ=0.3)	E.1 (KNcm ³ / m)	345	865	1620	3840
Alloy of Aluminium Layers					
Modulus of Elasticity	E (N / mm ²)	Rm: 145-1 85			
Tensile Strength of Aluminum	(N / mm ²)	Rp0, 2: 110-175			
0.2% Proof Stress	(N / mm ²)	A50>3%			
Elongation	(%)	2.0mm / m (100.C temperture difference)			
Linear Thermal Expansion					
Thermal Properties:					
Thermal Resisance	R (m ² K/m)	0.0047	0.0080	0.0113	0.0180
Heat Transition Coefficient	U (w / m ² k)	5.72	5.61	5.50	5.30
Range of Application	°C	-50~+80			

AluAd is the panel used for advertising/Signage

AluAd is the lightest at equal rigidity of products shown below



AluBuil/AluAd Available Colors

					
YS8111 Shiny Silver	YS8136 Glossy White	YS8114 Light Grey	YS8151 Cambridge Blue	YS8147 Fruit Green	YS8135 Glossy Red
					
YS8112 Silver Grey	YS8117 Pure White	YS8113 Bank Grey	YS8154 Telecom Blue	YS8152 finish Green	YS8128 Chinese Red
					
YS8144 Champagne	YS8118 Off White	YS8115 Dark Grey	YS8245 Glossy Telecom Blue	YS8148 Emerald Green	YS8127 Rose
					
YS8142 Silver Jade	YS8119 Ivory White	YS8123 Pink	YS8155 Dark Blue	YS8149 Post Green	YS8129 Pale Rose
					
YS8141 Bloom White	YS8122 Shiny Gold	YS8143 Brass Metallic	YS8138 Glossy Dark Blue	YS8137 Glossy Black	YS8132 Dark Coffee
					
YS8121 Advertising Yellow	YS125 Saffron Yellow	YS8124 Jacinth	YS8139 Glossy Jacinth	YS8140 Glossy Yellow	YS8116 Pure Black
					
YS8130 Brushed Silver	YS8133 Brushed Gold	YS8146 Shiny Black	YS8158 Royal Botticino	YS8157 Perlato Royal	YS8156 Perlato Svevo
					
YS8131 Silver Mirror	YS8134 Gold Mirror	YS8165 Walnut	YS8159 Rosa Norwegian	YS8160 Indian Red	YS8161 Purple Red
					
YS88047 Maple	YS8166 Teak	YS8162 Arabescato	YS8168 Brown Nets	YS8169 Nero Margiua	YS8170 Portoro

*Color can be customized, color number or samples needed.



PROTECTIVE FILM

The protective film on the sides protect the lacquered AluBuil/AluAd surfaces against damages that can occur during transportation, storage, processing or installation.

We recommend removing the protective film from the sheets as soon as possible after installation in order to avoid residues of glue sticking to the surface due to radiation and outdoor exposure. The

protective films and the panel surfaces may not be marked using ink(marker), adhesive tapes or stickers, as the lacquered surfaces could be damaged by solvents or plasticizers.

HANDLING

The pallets need to be handled carefully during transportation and unloading. Especially for the handling of large formats the individual panels should only be lifted off the pallets by two persons holding all four corners. The panels may not be drawn over each other. We recommend carrying the panels vertically and wearing gloves to avoid staining.

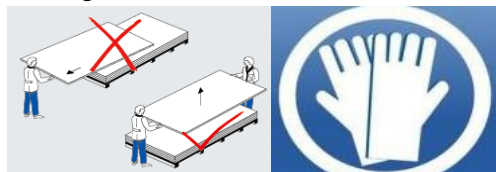

STORAGE

ALUBUIL/ALUAD pallets of the same size can be stacked however only with a maximum of 6 pallets stacked on top of each other.

A storage exceeding 6 months should be avoided. It is important to protect ALUBUIL/ALUAD pallets against rain, wetness, spray water and condensation (e.g. when transporting cold panels to warmer rooms) at any time while storing.

Prior to any processing steps the panels should go through an intermediate storage for 24 hours at temperatures between 18 °C and 20 °C. For short term storage between two processing steps we recommend underlying the sheets with polystyrene or with foam wedges.

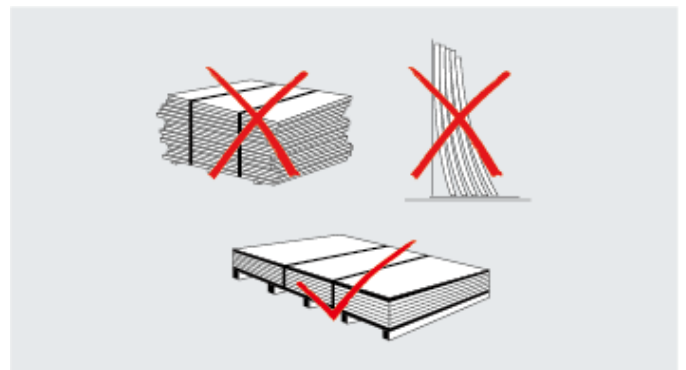
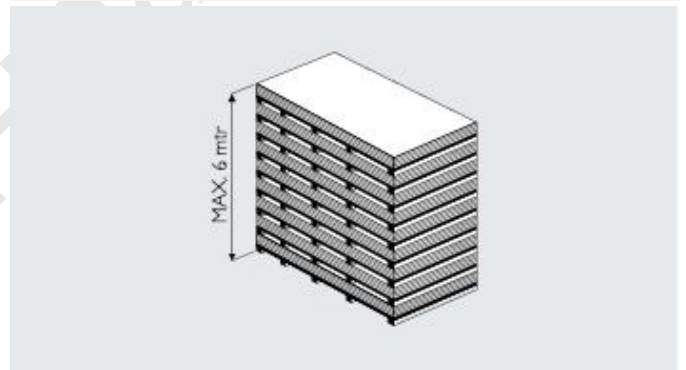
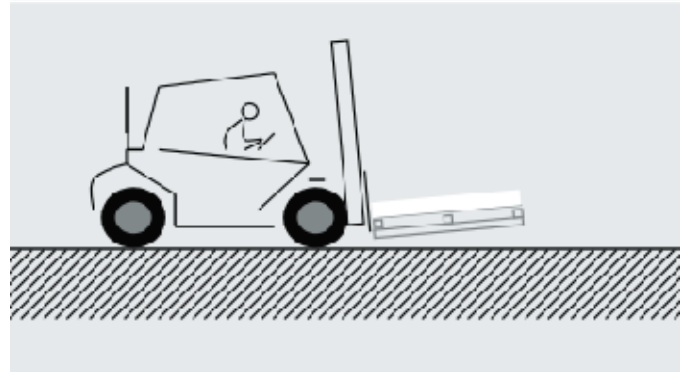
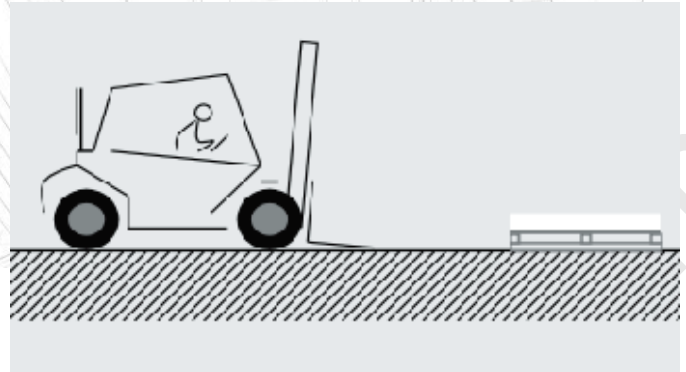
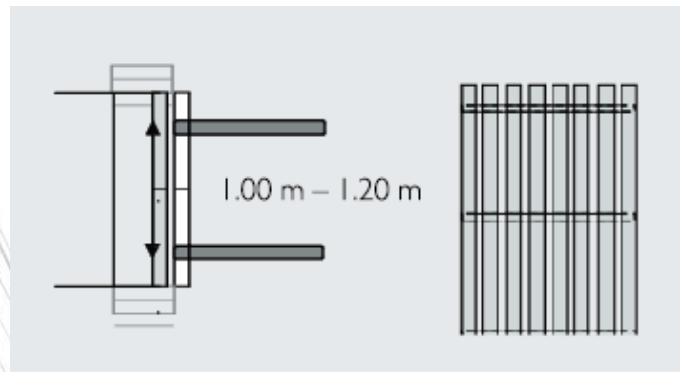

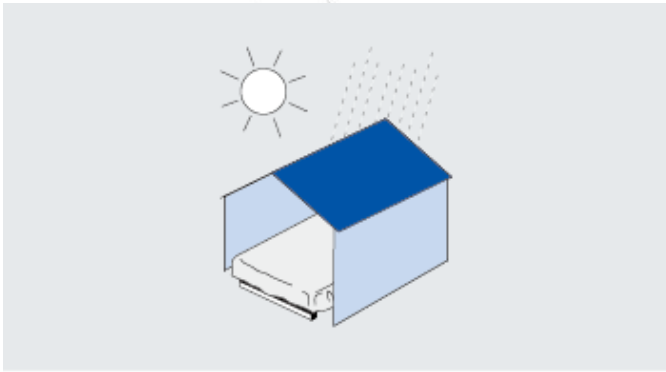

CLEANING & MAINTENANCE



Regular cleaning and the removal of dirt and aggressive deposits will not only maintain the aesthetic look of stove-lacquered surfaces

but also their value and quality. ALUBUIL/ALUAD surfaces should be cleaned either manually or with a suitable cleaning device from top to bottom. Abrasive pads may not be used on lacquered surfaces. Any powerful alkaline cleaning agents such as potassium hydroxide, sodium carbonate or caustic soda, or any powerful acidic products or heavily abrasive scouring agents would harm the lacquered surface and may therefore not be used. After the cleaning the surfaces should be washed with cold water in order to remove cleaning residues.

Cleaning of mirror like surfaces:

Even though ALUBUIL/ALUAD is handled with care, dirt and impurities such as finger prints can occur. Vlene or other fleece material for mirror surfaces with no liquid additives are suitable for cleaning. In case the dry cleaning should not be sufficient, water with a low surface tension can be used for pre-cleaning. The drying should again be done with a fleece cloth.

Any liquid cleaning agent should be pH-neutral and may not be abrasive. Cleaning agents for glass can be used if they correspond to the a.m. criteria.

We advise you to test the cleaning agent on an inconspicuous part of the ALUBUIL/ALUAD panel to check the usability.

Do not clean hot surfaces (> 40 °C) as the quick drying process may cause blemishes.

Expansion of ALUBUIL/ALUAD sheets

As ALUBUIL/ALUAD is used at temperatures between -50 °C and + 80 °C it is subject to thermal expansion or shrinking which needs to be considered when choosing the fixing system, fasteners and sealing. The linear thermal expansion of ALUBUIL/ALUAD is determined by the aluminum cover sheets and can be exactly calculated.

MACHINING FABRICATION TECHNIQUES

Cutting and Sawing



ALUBUIL/ALUAD can basically be cut or sawed with a vertical panel saw, circular or jig saw. The circular saw is applied for ALUBUIL/ALUAD in the

same as for full aluminum sheets. The vertical has proven ideal for serial cut, high cutting volumes and whenever an extremely high precision of the cuts is required. For ALUBUIL/ALUAD saw blades for cutting should be used. The cutting needs to be done on the reverse side of the panels. For cut-outs of the same format you can make cuts up to 5 panels.

There are three basic measures for a perfect cutting result:

- Keep your workplace clean in order to avoid scratches

on the ALUBUIL/ALUAD surface

- Use an appropriate vacuum cleaning system
- Work on the reverse side of the panel

Contour cutting, contour milling

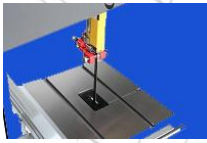

ALUBUIL/ALUAD can be cut to shape using jig saws, scroll saws, contour mills, CNC machining centres and water jet cutting machines.

- When cutting with jig saws, please use saw blades for wood and plastic materials
- Cut abrasively when using a water jet cutting machine. Pre-drilling of the panels is necessary when starting the contour cut in the middle of a panel as it is not possible to drill through with the water jet.
- For contour cutting on CNC machining centres use a one-edged cutter. Whenever absolute precision is requested, CNC-machines are the best solution in order to achieve the most accurate and detailed cuts and forms.

Drilling



ALUBUIL/ALUAD can be drilled with twist drills which are used for aluminum and plastics on common machines for metals. The best results are achieved with metal drills for stainless steel with a centre point and a point angle between 100° – 140°.

Punching



ALUBUIL/ALUAD panels of any thickness can be punched using standard metal punching machines.

Sharp tools and dies with minimal cutting clearance (0.1 mm) are important to achieve clear cuts. Punching will cause a slight deflection of the cut edge on the impact side. Holes of a minimum diameter of 4 mm can be punched. The minimum width of web between hole edges is also 4 mm. High volumes of the same punching format can be punched on serial punching machines.

Shearing



ALUBUIL/ALUAD can be easily sheared with a guillotine for thin sheets. Slight compressions of the aluminum cover sheet on the edges

may occur at the impact side. The clamp on the shear should be fitted with a shock-absorbing rubber pad to prevent damage to the cover sheet. Additionally corner-cutting tools can be used for punching

ALUBUIL/ALUAD sheets.

Fettling

We recommend a fettling tool with rotary blades or an abrasive pad for cleaning or deburring the edges of ALUBUIL/ALUAD.

Routing and Folding

For individual designs ALUBUIL/ALUAD can be shaped with the so called routing and folding technique which



allows a variety of shapes and design to be manufactured.

A V-shaped groove

is routed on the reverse side of the ALUBUIL/ALUAD using a disk or end milling cutter. The grooves can also be produced using a vertical panel saw with a routing device for ALUBUIL/ALUAD, on a CNC machining centre, with a panel routing machine or a hand routing machine. A thin layer of the core material needs to be left at the base of the groove, i.e. on the inside of the outer cover sheet. The outer cover sheet can then be bent manually, resulting in an exact and clean folding line which follows the routed groove. The outer radius of the folded edge depends on the shape of the groove and its depth.

The whole folding should be done in one action, exceeding the desired angle by 10 to 20 degrees.

Important - folding succour:

To bend a narrow and long ALUBUIL/ALUAD folding edge we recommend using a folding succour fabricated of a ALUBUIL/ALUAD panel strip and a joint profile (U/H-profile).

The routing and folding technique offers convincing advantages:

- Minimum investment for the production of individual ALUBUIL/ALUAD shapes
- Milling machines are inexpensive tools which are equally applicable for workshops or construction sites
- Serial parts can be produced economically on vertical panel saws
- Easy technique allowing many design possibilities
- Folding can be done manually on site, no pre-fabrication necessary, flat transportation - this means low costs for transport and storage.

■ Inexpensive production of shaped parts like interior claddings, shop fronts, furniture, POS displays, corner pieces,

■ Shapes are not restricted by machine dimensions
Please note: The routing and folding technique can be used for all ALUBUIL/ALUAD standard surfaces.

Bending



ALUBUIL/ALUAD can be formed three dimensionally by means of conventional metal and plastic fabrication methods. The minimum

bending radius is fifteen times the plate thickness.

Bending with a brake press:

ALUBUIL/ALUAD can be formed with a brake press just like full metal sheets. For this technique, the so called air-bending process is applied. The ALUBUIL/ALUAD panel rests on the edges of the die (rails, channels) and is bent by the punch (tube or shaft). The bending angle is determined by the width of the die and the stroke of the punch.

Bending with a folding machine:

When working with folding machines, ALUBUIL/ALUAD is clamped between two cheeks. The projecting edge is bent around the upper clamping cheek and former using the movable swivel bar. The bending radius is determined by interchangeable formers attached to the upper clamping cheek.

Bending with a roll bending machine:

ALUBUIL/ALUAD can be bent with roll bending machines as they are used for full metals – mainly with three- or four-roll machines

JOINTING AND FIXING TECHNIQUES

ALUBUIL/ALUAD can be joined by means of standard processes used in metal and plastics manufacturing.

If ALUBUIL/ALUAD needs to be joined to structural metal parts other than aluminum, or if fasteners (e.g. bolts, screws) are used, the following material guidelines need to be considered:

■ Fasteners and structural parts made of aluminum, plastic or stainless steel are applicable.

■ When using other materials insulating intermediate layers or protective coatings are required to prevent

corrosion.

■ For the outdoor use of ALUBUIL/ALUAD, its thermal expansion needs to be considered in order to avoid deformation.

■ The minimum hole clearance for the fixing material in the panel depends on and must be chosen according to the expected expansion of the panel in order to avoid restraints or deformation.

Riveting



ALUBUIL/ALUAD panels can be fastened together or joined to other materials with standard rivets for aluminum constructions. For outdoor use and areas of high humidity we recommend aluminum blind rivets with stainless steel mandrils in order to prevent corrosive edges. Countersunk rivets are suitable for indoor use only.

Please note: important for exterior riveting

As various factors may have an influence on the exact tolerance of the 0.3 mm thick rivets (e.g. rivet head tolerance), we recommend making a test on a panel.

The protective film in the riveting area needs to be removed prior to riveting.



Gluing

Gluing is a common jointing technique for ALUBUIL/ALUAD which is used for various applications.

We recommend the following gluing methods:

Metal adhesives / Universal adhesives

For indoor applications such as trade fair/exhibition stand structure, furniture or shop design universal adhesives or metal adhesives are most suitable.

Gluing tapes / velcro tapes

For applications with low requirements regarding tensile strength or shearing strength, double-sided tapes (such as the 3M-VHB high capacity jointing systems) can be used. For detachable joints we recommend Velcro® tapes such as SCOTCHMATE® or tapes known under the brand name Dual Lock®.

Adhesive sealing compounds

For elastic joints we recommend the one-component adhesive sealing compound SIKA BOND-T2 (POLYURETHANE BASIS)

This adhesive can be used outdoors for jointing parts of minor static importance.

Please note:

Please read the manufacturers instructions for the application and use of adhesives/ tapes carefully. Adhesives and sealing compounds do not adhere to the ALUBUIL/ALUAD plastic core (cutting edges). The gluing of ALUBUIL/ALUAD to other materials may result in deformation of one or both of the laminates due to the different expansion parameters of materials (bimetal effect).

The expansion of the panels with temperature changes has to be taken into consideration as well. In order to absorb the expansion we recommend to choose glues that provide enough elasticity.

Screwing

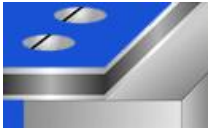

Fastening without forcing is possible using fascia screws made of stainless steel with sealing washers that have been approved for construction. It goes without saying that the screws must be suitable for the corresponding substructure.

Screws with different head-shapes for any metals or wood are suitable for indoor use. They do not normally allow for any panel expansion. Countersunk screws can be used with the standard countersinking method or by depressing the aluminum surface into the panel. When depressing the aluminum surface, the diameter of the hole in the panel needs to be larger than the screw diameter. Countersunk screws are suitable for indoor use only.

Please note for indoor and outdoor application:

It is important to remove the protective film in the screwing area prior to screwing.

Clamp connections



Especially for exhibition design, signage and display applications, clamp connections are a favored method to join materials.

Clamp connections out of aluminum or plastics are particularly suitable for ALUBUIL/ALUAD.

They generally consist of two parts with the clamping effect achieved by bolting. Various designs of clamping elements and aluminum profiles can be used for

shock-resistant and stiff indoor display and store fitting purposes. The inevitable tolerances show different retention forces.

A uniform and solid fit of the sections is obtained by pressing both sides of the profiles together. Butt joint, corner and edge profiles are available for panels of 3 mm, 4 mm and 6 mm thickness.

Hot air welding

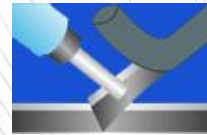

Hot-air welding is a standard technique for joining thermoplastics and has proven useful for welding of ALUBUIL/ALUAD as well. The plastic core and the plastic welding rod are heated and welded with electrical hot-air welding sets. The plastic core of ALUBUIL/ALUAD can be hot air welded by using a polyethylene welding rod. We do not recommend this method for constructive applications.

The following conditions are essential for good welding results:

- Well prepared welding joint
- Good quality welding rod
- Clean hot air
- Correct temperature
- Correct contact pressure
- Welding speed

SURFACE TREATMENT

Lamination & photo mounting with adhesive foils



ALUBUIL/ALUAD can be laminated (manually or by machine) with cast or calendered self-adhesive foils. Even when changing the foils for multiple

use of the ALUBUIL/ALUAD sheets, the varnish does not come off. Depending on the size of the foils, different methods of applying the film can be used. Photo mounting is either done with adhesive films or wet with dispersion adhesive. For manual lamination it is important to work with a scraper. This technique is mainly used for applications such as advertising signs, campaigns and event marketing, while photo designers appreciate the evenness and stiffness of the ALUBUIL/ALUAD panels combined

with their low weight.

It is important that the ALUBUIL/ALUAD surface is clean and free of dust and grease before foils or photos are laminated onto the surface.

Even after the lamination or photo mounting diverse fabrication techniques with ALUBUIL/ALUAD are still possible – e.g. the routing and folding technique or the forming of cassettes which adds visual depth to photo images.

Overlacquering– varnishing



Most customer requirements for special ALUBUIL/ALUAD colors are already met by our wide range of standard and complementary colors.

However for small volumes in very special colors which are not included in the ALUBUIL/ALUAD color range it might be worth to over lacquer ALUBUIL/ALUAD sheets. The fact that the aluminum pretreatment and the priming are already provided by the continuous process which ALUBUIL/ALUAD has gone through while being produced is definitely an advantage.

The working process of new ALUBUIL/ALUAD panels is as follows:

1. Pre-cleaning of the panels with Ethyl- or Isopropyl alcohol
2. Grinding the surfaces with wet abrasive paper (grain size 360)
3. Removing grinding dust with a lint-free cloth moistened with spirit
4. For the top coat, please follow the instructions of the top coat suppliers

Screen



Stove-lacquered ALUBUIL/ALUAD surfaces are well suited for screen printing. It is important to remove the protective film and to clean the surface using ethyl alcohol or isopropyl alcohol and a fluff-free cloth prior to printing. The alcohol must not be applied directly to the panel. Between cleaning and printing the alcohol needs approx.

10 – 15 minutes to evaporate. A lamination of the prints can be useful in order to achieve special surface effects or to improve mechanical or chemical properties.



Direct-to-substrate digital printing

As the polyester lacquered ALUBUIL/ALUAD surface is very flat and homogeneously smooth it provides outstanding ink adhesion and is printable on all standard flat bed printers. All standard ALUBUIL/ALUAD colors as well as most of the decorative ALUBUIL/ALUAD surfaces are ideal printing substrates and have proven excellent printing result during the past decade.

Since ALUBUIL/ALUAD is resistant to temperatures from +80 °C to -50 °C, resistant to water and UV, yellowing or distortion through UV lamps and sunlight does not occur. Hence, digitally printed signs can be used long term and keep their color quality even outside.

Regarding the pretreatment we recommend the same process as mentioned for screen printing. To avoid fingerprints on the surface gloves are the easiest solution. Various processing techniques such as routing, folding or bending are possible with ALUBUIL/ALUAD - even after printing with solvent based inks.



General Methods of Installation

Example of Panel Type and Joint Design

- 1. AluBuil/AluAd panel
- 2. Aluminum rivet
- 3. Angle aluminum
- 4. Sealing material
- 5. Bach spacer
- 6. Spacer
- 7. Angle bar
- 8. Bullen Screw

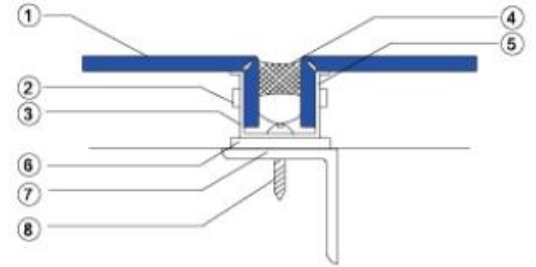
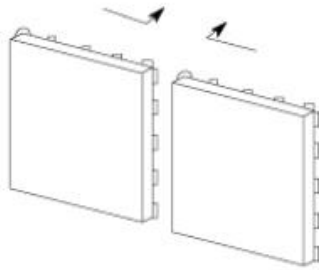

Example of Panel Type and Joint Design

- 1. AluBuil/AluAd panel
- 2. Aluminum rivet
- 3. Angle aluminum
- 4. Angle aluminum
- 5. Sealing material
- 6. Bach spacer
- 7. Spacer
- 8. Angle bar
- 9. Bullen Screw

Angle aluminum and seal joint (1)

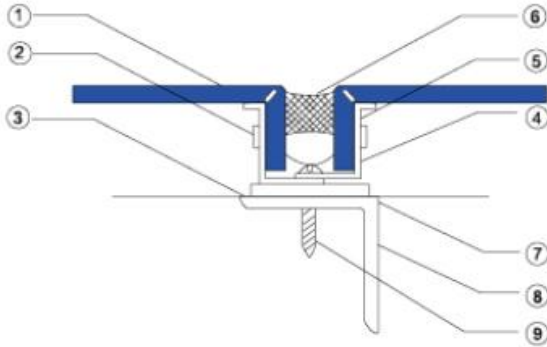

Angle aluminum and seal joint (2)

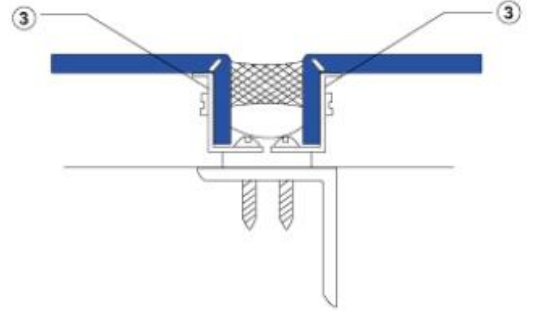

Example of Panel Type and Joint Design

Accessories and seal joint (1)

- 1. AluBuil/AluAd panel
- 2. Sealing material
- 3. Plastic lining bar
- 4. Accessories
- 5. Spacer
- 6. Angle bar
- 7. Bullen Screw

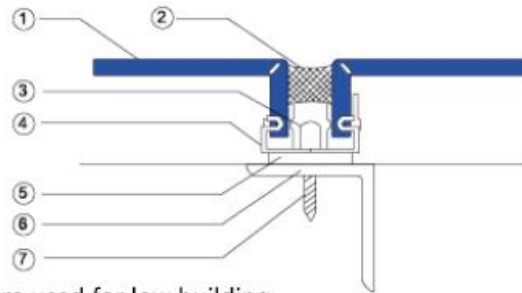

Accessories and seal joint (2)

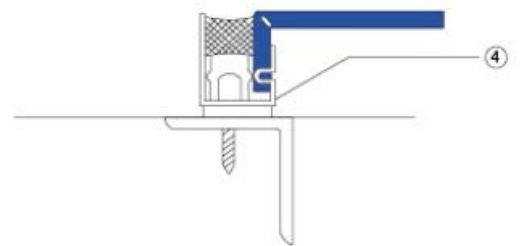

Above mentioned accessories are used for low building

Example of Panel Type and Joint Design

- 1. AluBuil/AluAd panel
- 2. Aluminum rivet
- 3. Angle aluminum
- 4. Angle aluminum
- 5. Gasket
- 6. Spacer
- 7. Angle bar
- 8. Bullen Screw

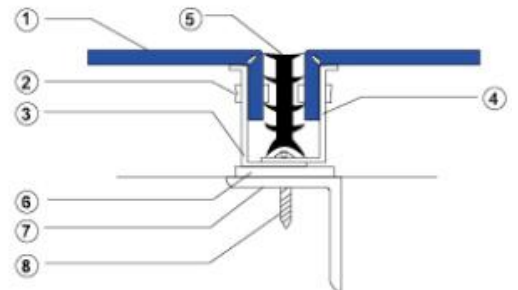
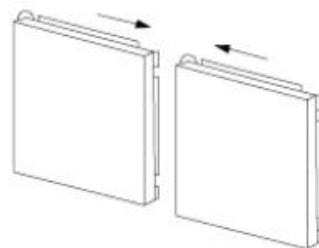

Example of Keel Structure

1. AluBuil/AluAd panel
2. Bearing strut
3. Angle support
4. Welding
5. Angle bar

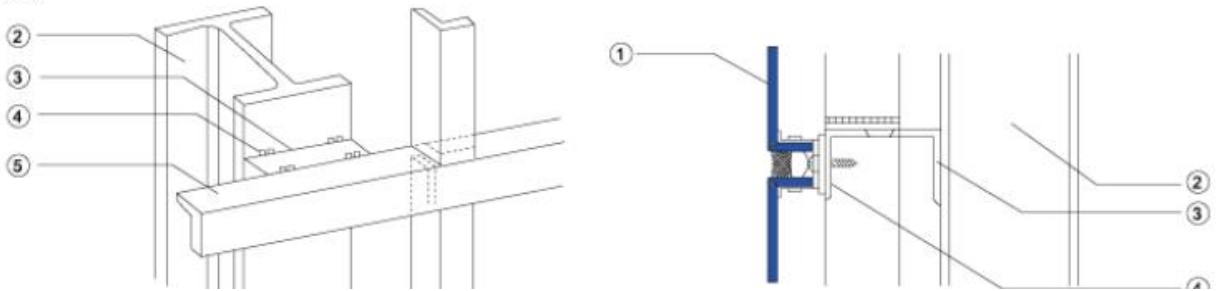

Example of Keel Structure

1. AluBuil/AluAd panel
2. Bearing strut(wall)
3. Angle support
4. Angle aluminum
5. Tapping screw
6. Embedded part

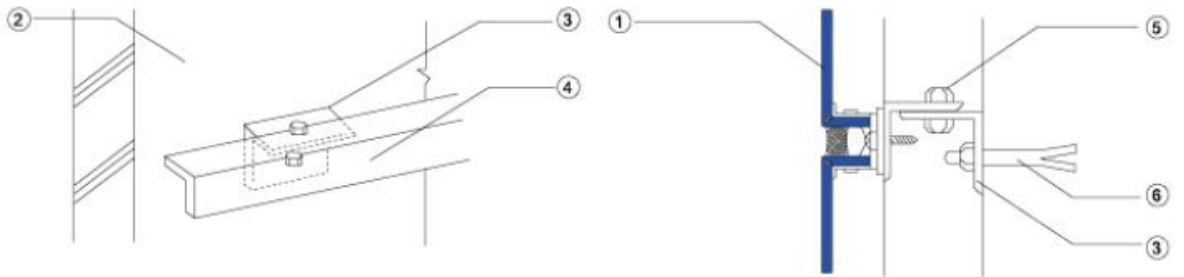

Installation Example of Building Top

1. AluBuil/AluAd panel
2. Building top
3. Angle support
4. Angle support
5. Angle bar
6. Sealing material
7. Lining material
8. Bullen Screw
9. Built-in anchoring or expanding bolt

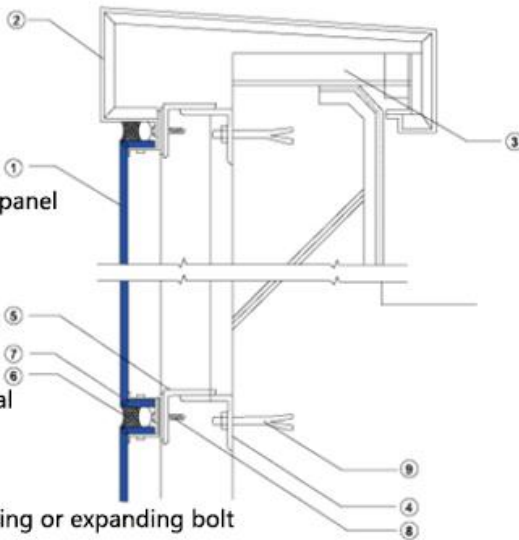

Installation Example of Eaves

1. AluBuil/AluAd panel
2. Angle support
3. Angle bar
4. Built-in anchoring or expanding bolt
5. Sealing material
6. Lining material
7. Bullen Screw
8. Ceiling

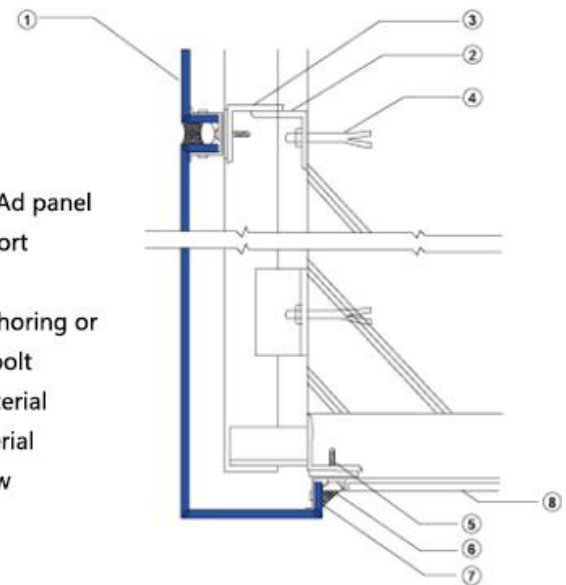

Example of Column Corering

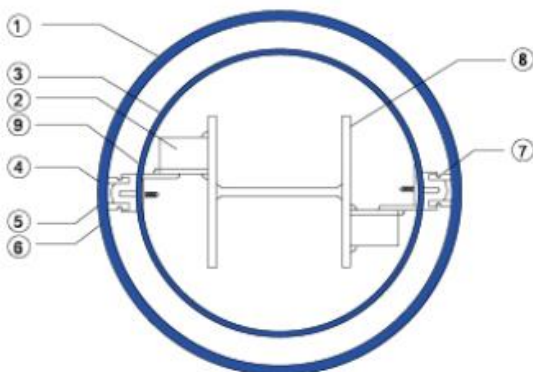

1. AluBuil/AluAd panel
2. Angle support
3. Steel plate strip
4. Sealing material
5. Plastic lining bar
6. Accessories
7. Bullen screw
8. Bearing strut

Above mentioned accessories are used for low building

Installation Example External Corner

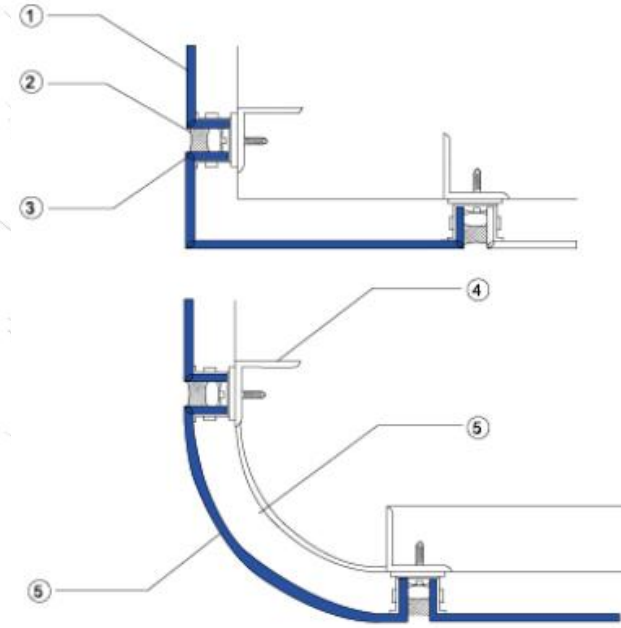

- 1. AluBuil/AluAd panel
- 2. Sealing material
- 3. lining material
- 4. Angle bar
- 5. Steel plate strip

Installation Example of Installation Corner

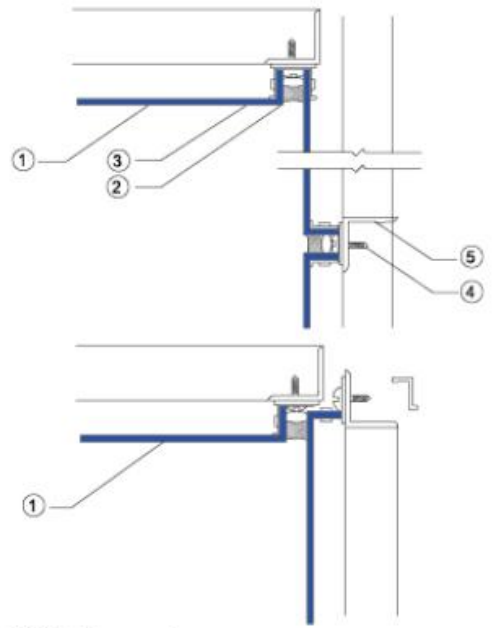

- 1. AluBuil/AluAd panel
- 2. Sealing material
- 3. lining material
- 4. Angle bar
- 5. Bullen Screw



Contact Information:

Shanghai YoSu New Materials Co., Ltd.

Office Address: No.77 Songbin Road, Baoshan District, Shanghai

Tel: +86 21 56452911

Fax: +86 21 56452911

Email: info@yosu-materials.com